

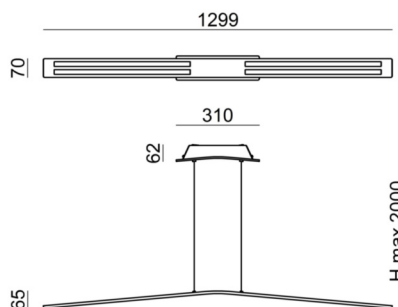

Pendant Luminaires | 220-240 V | topLED 45 W 24 V | CRI 85
7106



Technical data	
Installation position	Ceiling
Installation environment	Indoor
Light Source	LED
Optics	General Lighting
Light emission direction	downward and upward
Power	45 W
Luminous flux (source)	3241 lm
Frequency	50 - 60 Hz
CCT / Tonaltà	3000 K
Colour rendering index	85 Ra
Safety class	1
IP	IP40
Glow wire test	850°
Direct mounting on normally flammable surfaces	Yes
CE	Yes
ETL	No
Driver included	Yes
Induzione	No
Emergency mode	No
Motion sensor	No
Directional	No
Tilting	No
Walk-over	No
Drive-over	No
Cable included	No
Resin potting	No

Finishing casing	
Material	Aluminium
Colour	embossed white RAL 9003
Processing	Coating

Finishing diffuser	
Material	PC
Colour	opaline

Finishing mounting frame	
Material	Iron
Colour	embossed white RAL 9003
Processing	Coating



Pendant Luminaires | 220-240 V | topLED 45 W 24 V | CRI 85
7106

Double emission pendant luminaires for indoor application. The warm white LED light source with a general lighting light distribution is composed of 156 topLEDs with CCT of 3000 K and a CRI 85; the source luminous flux is 3241 lm, with a 72.0 lm/W nominal luminous efficacy and an operating lifetime (L80) of 80000 hours.

The device body is made of aluminium and features a embossed white ral 9003 finish, processed by means of coating; the diffuser is made of PC; the mounting frame is made of iron, with a embossed white ral 9003 finish, processed by means of coating. The ingress protection degree is IP40; the total weight is of 4.3 kg. The power supply driver is included in the delivery.

The total absorbed power is 45 W.

The device features protection class I and can be ceiling-mounted.

Illuminotechnical Features	
Light Output Ratio (LOR)	74 %
Luminous flux (source)	3241 lm
Luminaire luminous flux	2414 lm
Consumption	45 W
Luminaire efficacy	53 lm/W
Colour temperature	3000 K
Standard Deviation of Colour Matching	3 Step MacAdam
Colour rendering index	85 Ra

UGR	
X=4H Y=8H	S=0.25H
Reflection factor	70/50/20
UGR transversal	< 19
UGR axial	< 16

OPTICAL	
Light distribution simmetry	Asymmetrical
Ottica C0/C180	140°
Ottica C90/C270	114°

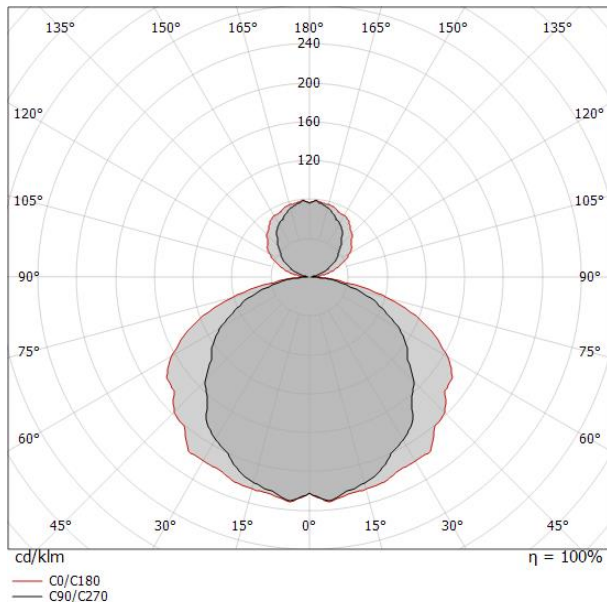

Distance [m]	Cone diameter [m]	E(0°)	E(C90)	E(C0)	Illuminance [lx]
0.5	1.55 2.76	2148	57.2° 178	70.1° 44	
1.0	3.10 5.52	537	57.2° 44	70.1° 11	
1.5	4.66 8.29	239	57.2° 20	70.1° 5	
2.0	6.21 11.05	134	57.2° 11	70.1° 3	
2.5	7.76 13.81	86	57.2° 7	70.1° 2	
3.0	9.31 16.57	60	57.2° 5	70.1° 1	

Distance [m] Cone diameter [m] Illuminance [lx]

— C0/C180 (Half-peak divergence: 140.2°)
— C90/C270 (Half-peak divergence: 114.4°)