



Product code	Colour
717-369-21	Mat white
717-369-16	Black
717-369-52	Silver, on demand

General Specifications

Product type	: Spotlights
Mounting type	: LKM 3-phase track
Description	: Minikyclos is a compact spotlight for electrified tracks, specially developed for high efficiency COB LED sources of the last generation. It is characterized by an innovative system of passive heat dissipation. Body in die-cast aluminium without visible screws, with a front part in clear polycarbonate, rear painted for a brighter finish. Professional optics to get different beam angles and optical devices for a better visual comfort are available as accessories.

Indoor/outdoor lights	: Indoor
Applications	: Museums, Retail ,Shops, Showrooms

Lighting specifications

Average lamp life (h)	: 50.000
Lamp description	: LED 3150lm 27W 3000K
Nominal lumens on thermal regime	: 3150
Efficiency L.O.R. (%)	: 92,6
Delivered lumens (lm)	: 2917
Lamp wattage (W)	: 27
Color temperature (K)	: 3000

Physical Specifications

Body	: Die-cast aluminium
Finishes	: Polyester painted
Reflector	: Mirror-metallized thermoplastic material
Thermal Dissipation	: Passive

Electrical Specifications

Glow wire (°C)	: 850
Driver	: Included
Driver mounting	: Integrated
Voltage (V)	: 220/240
Frequency (Hz)	: 50/60

Weight and Dimensions

Width (mm)	: 126
Height (mm)	: 88
Weight (Kg)	: 0.9

Optical Specifications

Light distribution	: Symmetric
Light emission	: Direct
Light beam	: 30°
Horizontal orientation	: 350°
Vertical tilt	: 350°
Note	: 17°, 55° (mirror metallized), 70° (white) optics are available on demand. Honeycomb code 28-3959-30, clear tempered glass code 28-3958-58, pink tempered glass for food applications code 28-3958-32 to be used only together with snoot code 28-3957-30.

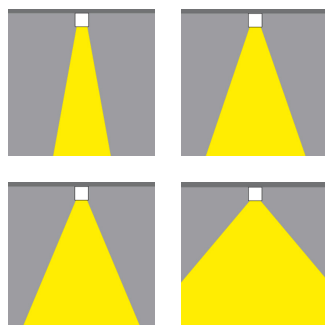
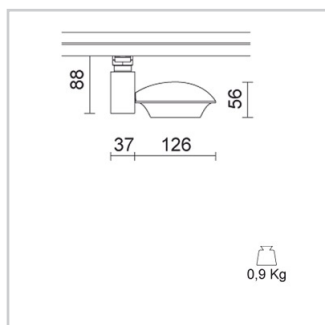

Unified Glare Rating (U.G.R.) : <19

Accessories

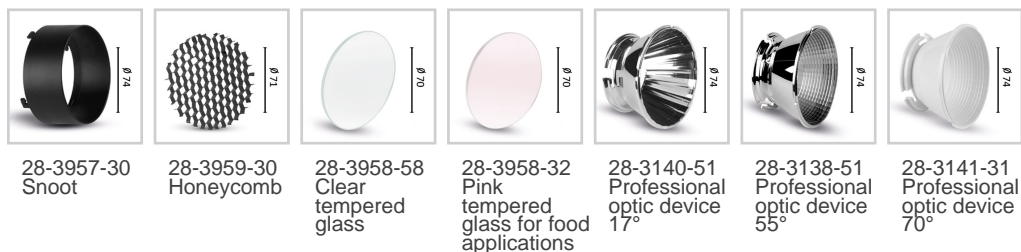

Pictures and Applications

