

Code: 7861  
 Collection: SNAKE  
 Version: 00 Date:  
 Brand: Linea Light

linea  
light  
group

Istruzioni per l'installazione  
 Installation instructions  
 Instrucciones para la instalación  
 Instructions pour l'installation  
 Installationsanleitung

ATTENZIONE: la sicurezza dell'apparecchio è garantita solo con l'uso appropriato delle seguenti istruzioni; pertanto è necessario conservarle.  
 GARANZIA: I prodotti devono essere installati tassativamente con alimentazioni, cablaggi e accessori originali del Gruppo Linea Light, o eventualmente approvati dall'azienda. L'utilizzo di accessori non originali, o non approvati, determina il decadimento di ogni garanzia sul prodotto.

WARNING: the safety of this fixture is guaranteed only if you comply with these instructions; remember to conserve in a safe place.  
 WARRANTY: All power supply, wiring and accessories used for product installation shall be original Linea Light Group parts or approved by the company. The warranty will become void if non original or non approved parts are used.

ATENCIÓN: la seguridad del aparato se garantiza solo cumpliendo cuidadosamente las siguientes instrucciones; por ello, es necesario conservarlas.  
 GARANTÍA: Los productos se han de instalar obligatoriamente con alimentaciones, cableados y accesorios originales de Linea Light Group o, de otra forma, deben ser aprobados por la empresa misma.  
 El uso de accesorios no originales, o no aprobados, anula todas las garantías del producto.

ATTENTION: la securite de l'appareil n'est garantie qu'en cas d'utilisation correcte des instructions suivantes; il faut par consequent les conserver.  
 GARANTIE: Les produits doivent impérativement être installés avec des alimentations, des câblages et des accessoires Linea Light Group, ou qui ont été approuvés par l'entreprise.  
 L'utilisation d'accessoires non d'origine, ou non approuvés, entraîne la déchéance de toute garantie sur le produit.

ACHTUNG: die sicherheit des gerates wird nur durch sachgemasse befolgung nachstehender anweisungen gewährleistet; ihre aufbewahrung ist deshalb sehr wichtig.  
 GARANTIE: Die Produkte müssen obligatorisch mit Originalstromversorgung, Originalkabeln und Originalzubehör der Linea Light Group oder mit Teilen, die von der Linea Light Group ausdrücklich empfohlen sind, installiert werden. Die Verwendung von nicht originale oder nicht vom Hersteller empfohlenem Zubehör führt zu einem sofortigen Verfall vom Garantieanspruch für das Produkt.

Contenuto dell'imballo - Box Contents - Contenido de la confección - Contenu de l'emballage - Packungsinhalt

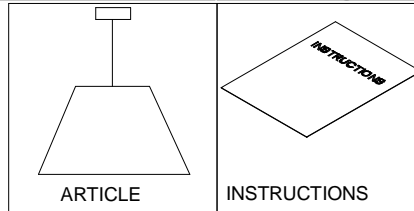

1

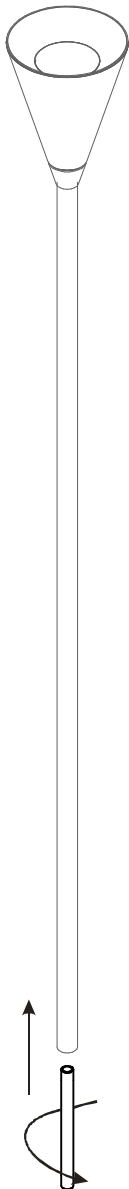

2

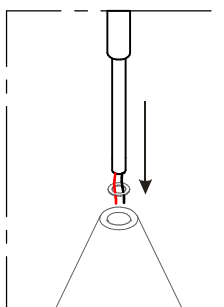
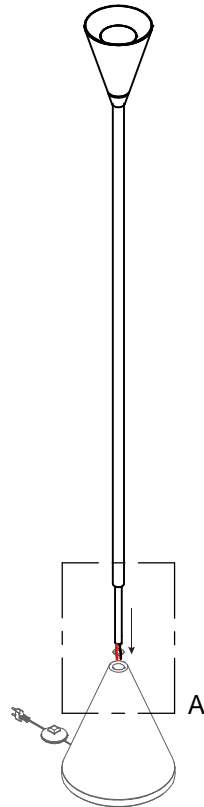

DETTAGLIO A

3

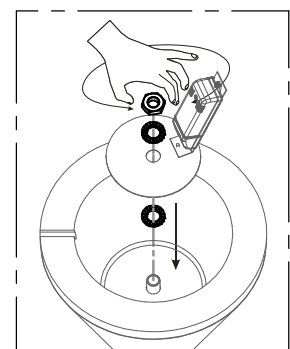
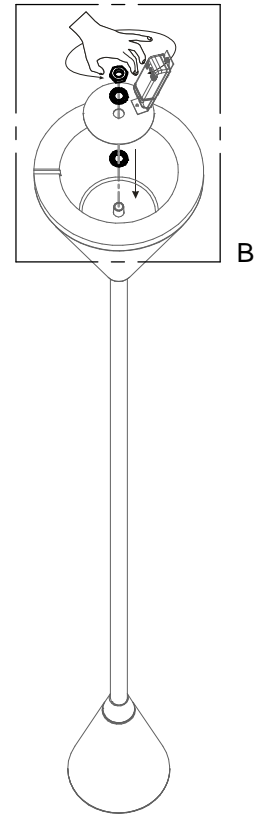

DETTAGLIO B

Code: 7861  
Collection: SNAKE  
Version: 00 Date:  
Brand: Linea Light

linea  
light  
group

Istruzioni per l'installazione  
Installation instructions  
Instrucciones para la instalaci3n  
Instructions pour l'installation  
Installationsanleitung

4

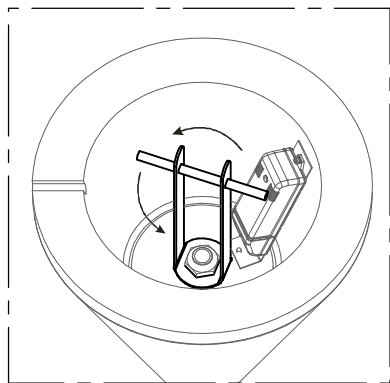
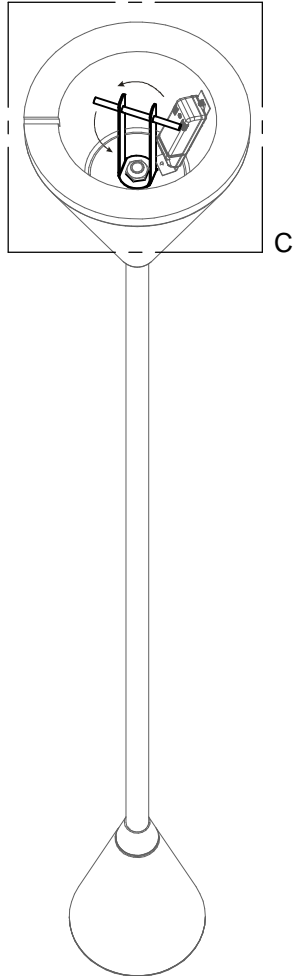

DETTAGLIO C

5

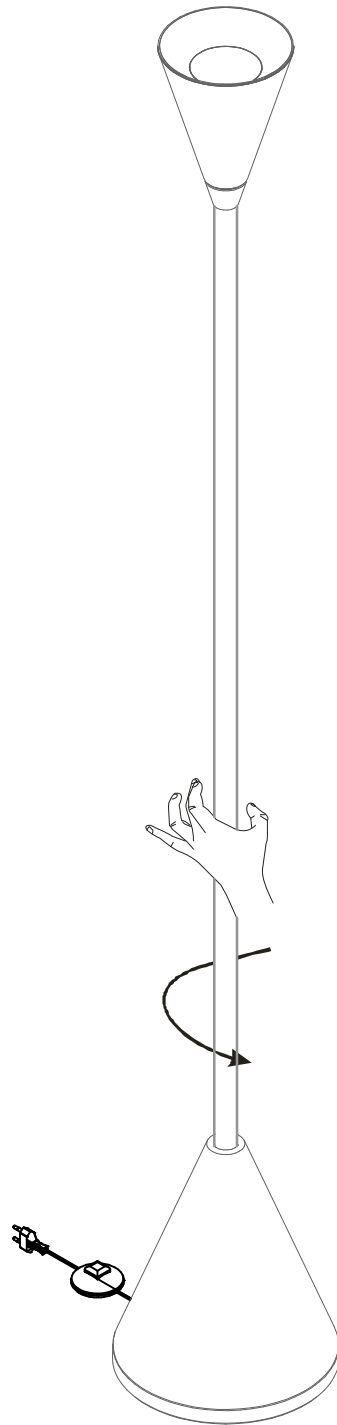

6

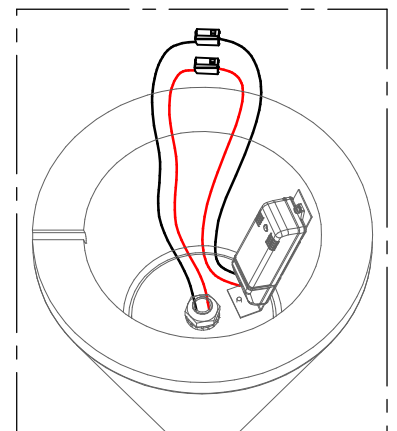
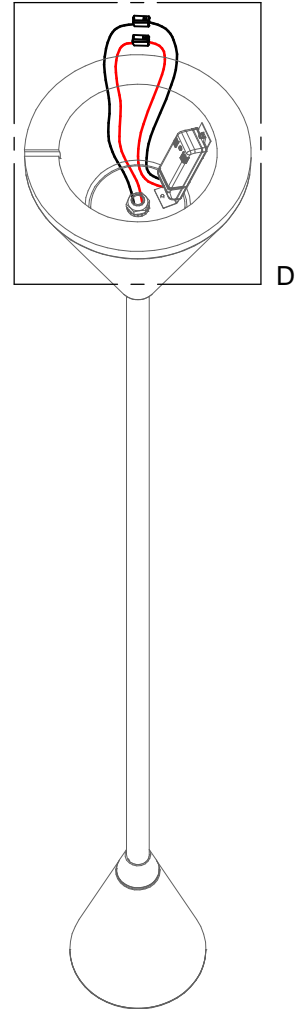

DETTAGLIO D

Code: 7861  
Collection: SNAKE  
Version: 00 Date:  
Brand: Linea Light

linea  
light  
group

Istruzioni per l'installazione  
Installation instructions  
Instrucciones para la instalaci3n  
Instructions pour l'installation  
Installationsanleitung

7

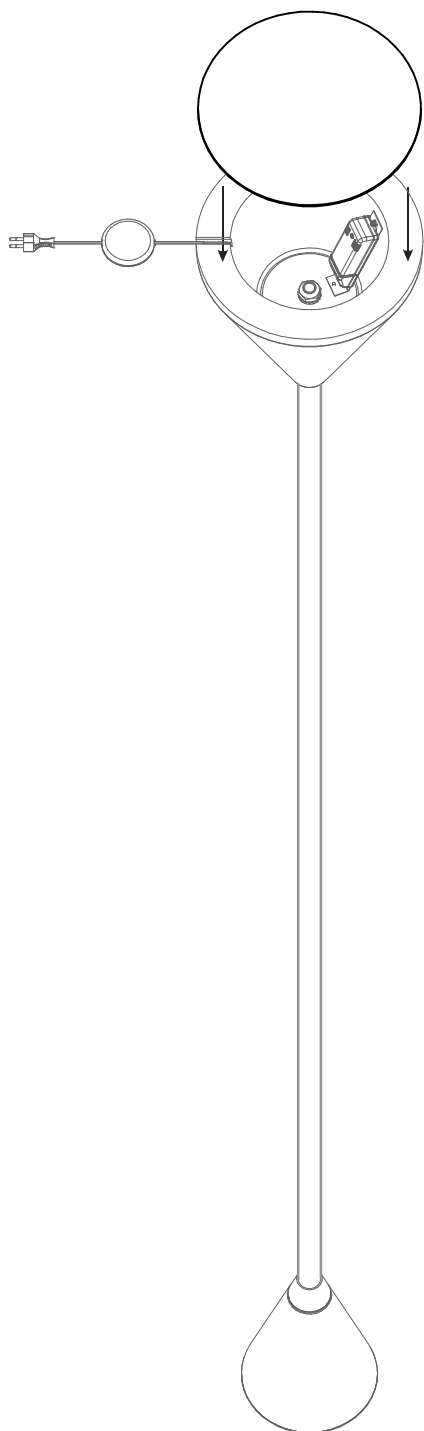

8

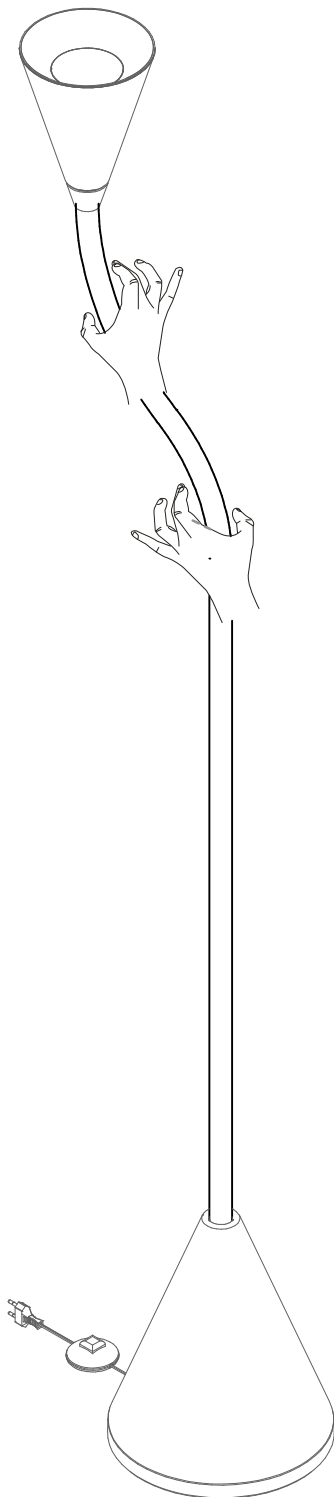

9

- INTERRUOTORE ON-OFF
- SWITCH (ON-OFF)
- INTERRUPTOR (ON-OFF)
- INTERRUPTEUR (ON-OFF)
- SCHALTER (ON-OFF)

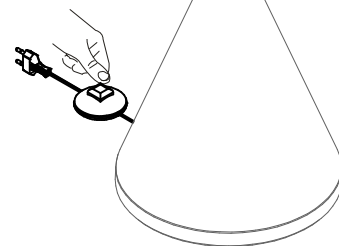

-Per regolare la lampada, non agire sulla testa ma sul tubo flessibile.  
-To adjust the lamp use the hose, not the lamp head.  
-Pour r3gler la lampe, ne pas agir sur la t3te mais sur le tube flexible.  
-Zum Verstellen die Lampe nicht oben am Lampenschirmanfassern, sondern am flexiblen R3hr.  
-Para regular la l3mpara, no actuar en la cabeza sino en el tubo flexible.